

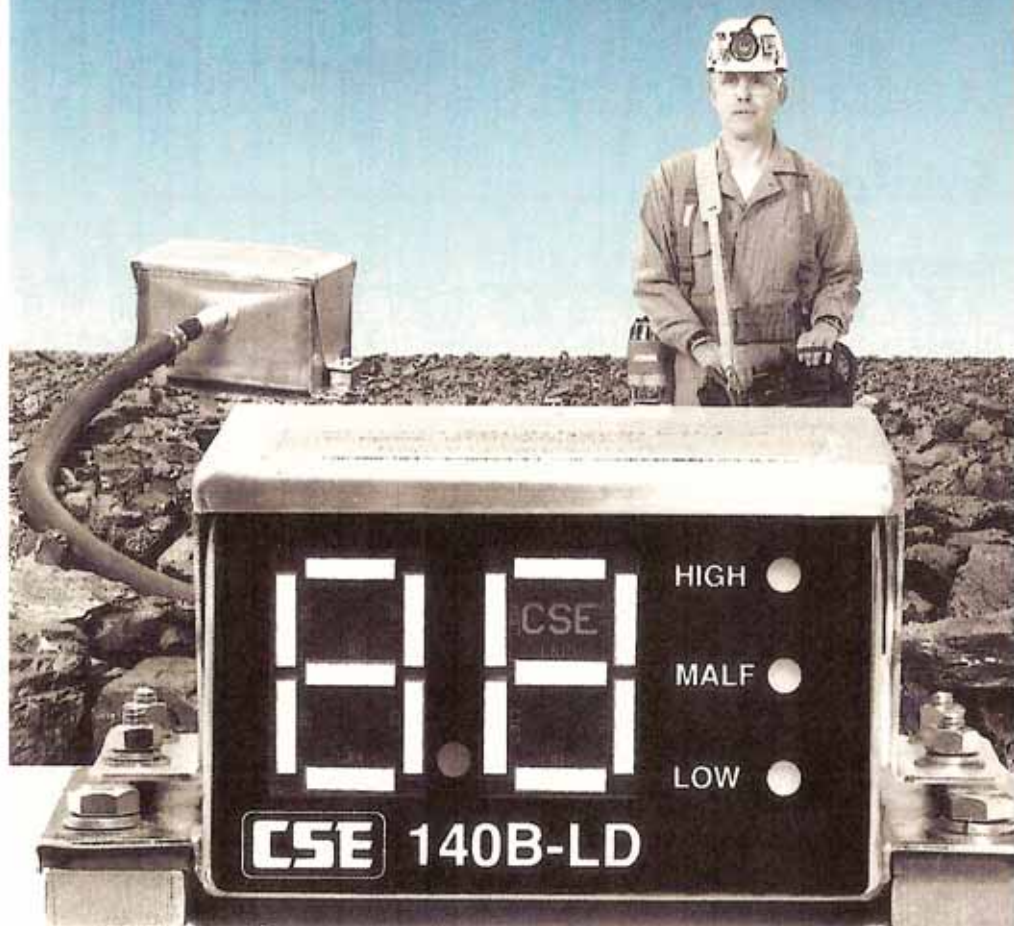

CORPORATION

140B CONTINUOUS METHANE MONITORS OWNERS MANUAL



WARRANTY

CSE Corporation warrants that this monitor system is free of defects in materials and workmanship, and that it will perform satisfactorily in the application for which it is intended, if it is used in accordance with the manufacturer's instructions.

This warranty is applicable ninety (90) days from the date of purchase by the original user. The product under warranty, returned to CSE with prior approval, will be carefully examined. If the product proves to be defective and not abused, misused, altered or damaged, CSE will repair or replace it free of charge.

This warranty expresses the full extent of our intended liability, and may not be construed as covering any removal or replacement costs, or contingent expenses of any other nature.

CSE Corporation

CONTENTS

Section 1: Operation	Pg. 1
Section 2: Installation	Pg. 1
Section 3: Troubleshooting	Pg. 3
Section 4: Calibration	Pg. 4
Section 5: System Components	Pg. 5
Fig. 1	Pg. 6
Fig. 2 & Fig. 3	Pg. 7
Fig. 4 & Fig. 5	Pg. 8
Fig. 6 & Fig. 7	Pg. 9
Fig. 8	Pg.10
Fig. 9	Pg.11
Fig. 10 & Fig. 11	Pg.12
Fig. 12 & Fig. 13	Inside back cover

Ordering Information

When components or parts are needed, please contact your CSE Sales Office, your CSE Sales Representative, or your local distributor.

Section 1

OPERATION

1. CONTROLS AND INDICATORS

1.1 Low Alarm LED

Low alarm comes on when at least 1.0% methane is detected and turns off when the methane concentration drops to below 0.9%.

1.2 High Alarm LED

High alarm comes on when 2.0% methane is detected. At the same time, the machine control relay in the power supply unit will de-energize the machine. The control unit automatically resets when the methane concentration level drops below 1.9%.

1.3 Malfunction LED

Malfunction LED comes on when a malfunction occurs, such as a broken or disconnected cable between the control unit and the detector unit, a faulty detector unit (in most cases), a faulty control unit component, or out of calibration. The system will simultaneously de-energize the machine control relay which shuts down the machine. Re-energizing the relay is not possible until the malfunction has been corrected.

See troubleshooting section. (Page 3).

1.4 Test Pushbutton

The test pushbutton is used to check the operation of the system, making sure all the lights and digital displays are in working order. Test Pushbutton must be held in momentarily to initiate test sequence. This is to guard against accidentally starting test sequence. Test sequence is automatic on power up.

1.5 Zero & Span Potentiometers

The zero & span potentiometers are located in the control unit and are used to set the zero and span setting. Turning potentiometer clockwise increases the reading on the display (more positive). Turning potentiometer counter clockwise decreases the reading on the display (more negative).

See figures 2 & 3 for location.

Section 2

INSTALLATION

CAUTION: All system interconnect cables *must* be disconnected before welding.

2.1 Weldplate - All system components

Tack weldplate in position. Remove component housing and rubber shock mounts. Finish welding weldplate in position. After weldplate has cooled, replace shock mounts and component housing with stainless steel nuts and washers.

Section 2

INSTALLATION *(continued)*

- 2.2** **Detector Unit**
Position the detector unit in a suitable location on the machine near the cutting head. DO NOT position the detector unit such that the baffle cap faces upwards. A minimum of 30 degrees downward angle is recommended. Avoid exposing detector unit to water sprays. Allow room for removal of the baffle cap.
- 2.3** **Control Unit**
Position the control unit so the displays are easily visible. Allow sufficient room for access to the cover for calibration and maintenance.
Wiring connections to the control unit are made through the rear panel. **See Fig. 2 & 3.**
Note: If the system is placed on a DC powered machine in which the DC minus is not frame ground, the control unit must be mounted so its case is isolated from the machine frame.
- 2.4** **Auxiliary Display Unit**
Position the auxiliary display unit so the display is easily visible. Leave sufficient room to allow access for maintenance. The auxiliary display unit is connected to an auxiliary compatible control unit with an auxiliary display cable. The auxiliary display cable is terminated with one way fit connectors, **See Fig.13.**
Note: If the system is placed on a DC powered machine in which the DC minus is not frame ground, the auxiliary display unit must be mounted so its case is isolated from the machine frame.
- 2.5** **Dual Interface Unit**
When positioning the dual interface unit, allow room for wiring and maintenance. **For wiring see Fig. 4.**
Note: If the dual interface unit is placed on a DC powered machine in which the DC minus is not frame ground, the dual interface unit must be mounted so its case is isolated from machine frame.
- 2.6** **AC Power Supply/DC Inverter**
Keep housing cover in place during mounting. Position housing so that it is protected from water. Allow room for access to the inside of the housing and to the cable connection entries.
Note: If the system is placed on a DC powered machine, the copper grounding strap inside the power supply must be removed from its attachment bolt. For wiring the AC power supply, **See Fig.5.** For wiring the DC inverter, **See Fig.6 & 12.**

Section 2

INSTALLATION *(continued)*

2.6.1

XP Gland Packing

Refer to the MSHA Title 30-18.37 lead entrances.

See Fig. 7.

2.7

Remote Run-Light System

See Fig. 5 for a typical connection.

Note: Customer is to supply machine run light and power for its operation. The machine run light should require 10 AMPS or less at 120V AC or less.

2.8

Roof Bolter Auxiliary Panel

When positioning the roof bolter auxiliary panel, allow room for wiring and maintenance. See Fig. 10 & 11 for dimensions and wiring diagrams.

Section 3

TROUBLESHOOTING

3.1

Display shows a steady number (not flashing) between 0.1 and 5.0, Malfunction light on, Hi and Lo alarms off.

- Zero has drifted negative, Recalibrate system.

3.2

Display not lit.

- No 9V DC output from the power supply.
- Loading of the 9V DC somewhere in the system.
- Failure of the control unit.

3.3

A. Display shows a steady (not flashing) number between 0.0 and 9.9, Malfunction light on, Hi and Lo alarms off.

B. Display flashing, Malfunction light off, Hi and Lo alarms on.

- System out of calibration, attempt to recalibrate.
- Loose connection between detector unit and control unit.
- Break in the detector cable.
- Failure of the detector unit.
- Failure of the control unit.

3.4

Display periodically flashes on and off.

- Loose power supply connections.
- Intermittent overload somewhere in the system.
- Loose components in the control unit or power supply.
- Foreign objects (loose screws, etc.) vibrating on control unit circuit boards.

3.5

Erratic wander of zero.

- Water and/or dirt contamination of the detector unit.
- Water and/or dirt in the detector unit connector.

Section 3

TROUBLESHOOTING *(continued)*

- 3.5 Erratic wander of zero. (continued)
- Water and/or dirt in the detector unit connections in the control unit.
 - Loose detector connections in the control unit.
- Note:** To verify contamination of detector unit, rap the detector unit sharply. If the zero jumps around, there is a contaminate. Replace detector unit.
- 3.6 A. Unable to hold a stable zero (drift), or...
B. System has low or no response to calibration gas.
- Contamination of the detector unit (water, dirt, etc.).
 - End of detector unit service life.
- 3.7 Remote run lamp inoperative.
- Faulty lamp in remote indicator.
 - Faulty solid state relay on power supply.
 - Faulty power supply cable.
 - Faulty control unit.
- 3.8 Roof Bolter Auxiliary Panel inoperative
- Blown fuses
 - No power to panel
 - Faulty slave relay
 - Faulty Run Lamp transformer

Section 4

CALIBRATION

Calibration Procedure

- 4.1 Allow system to warm up for 5 minutes prior to calibration.
- 4.2 Remove the baffle cap and check that all holes and screens are free of any dirt or obstructions. Re-install baffle cap.
- 4.3 In fresh air or by using zero air, set the zero pot so the control unit display shows 0.0. Be sure to set to the center of the 0.0 range.
- 4.4 Place the calibration cup over the baffle cap.
- 4.5 Apply span gas of a known concentration at 1.0 SCFH (0.5 liters/min.). Let the control unit display stabilize.
- 4.6 Set the span pot so the control unit display shows the span gas concentration.
- 4.7 Remove calibration cup and let the detector unit clear.
- Note:** In instances where a large number of turns of the span pot are necessary to bring the control unit into calibration, the zero may shift slightly. This will be noticed after the detector unit has cleared. If the zero has shifted after the detector unit has cleared, repeat the calibration procedure a second time.

140B System

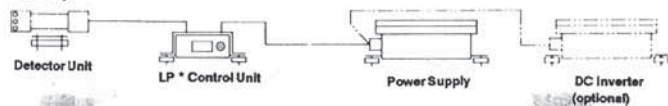

140B Dual System

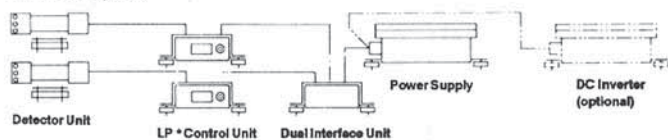

140B-LD System

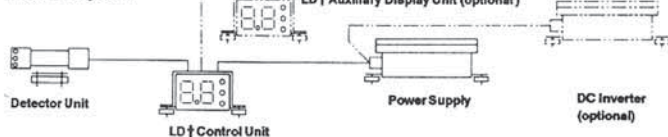

140B-LD Dual System

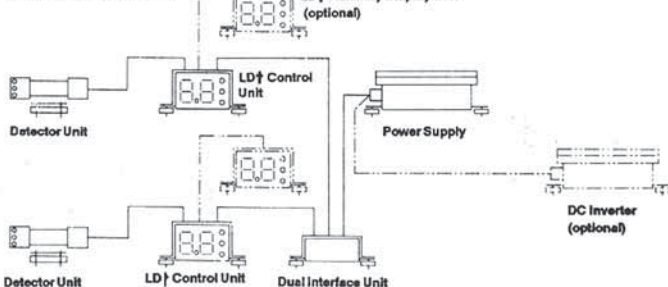

* LP Low Profile control unit see Fig. 2 for dimensions.

† LD Large Display control unit see Figs. 2, 3, & 13 for dimensions.

Fig. 1
140B
Detector Unit
Outline

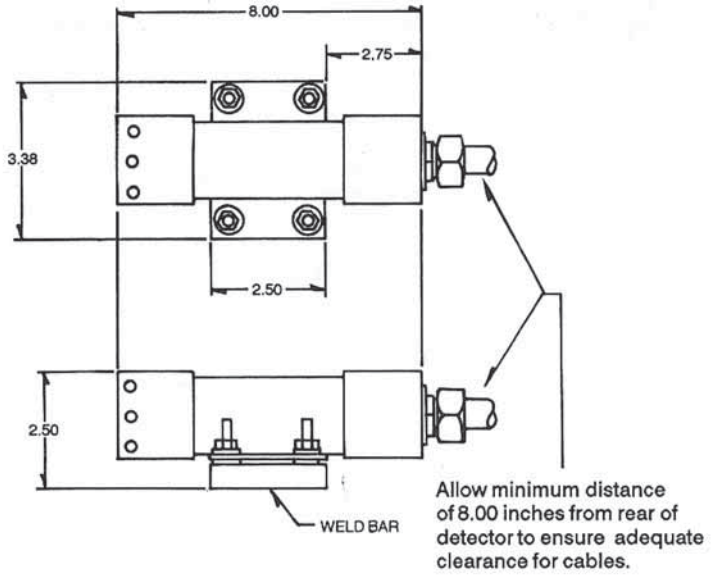

140B
High Velocity
Detector Unit
Outline

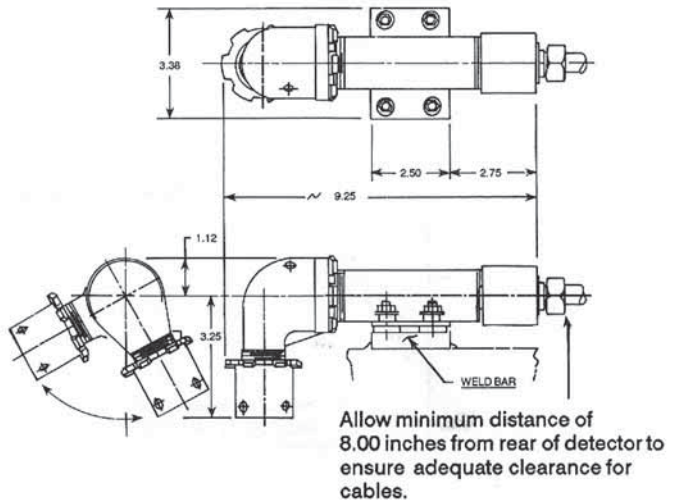
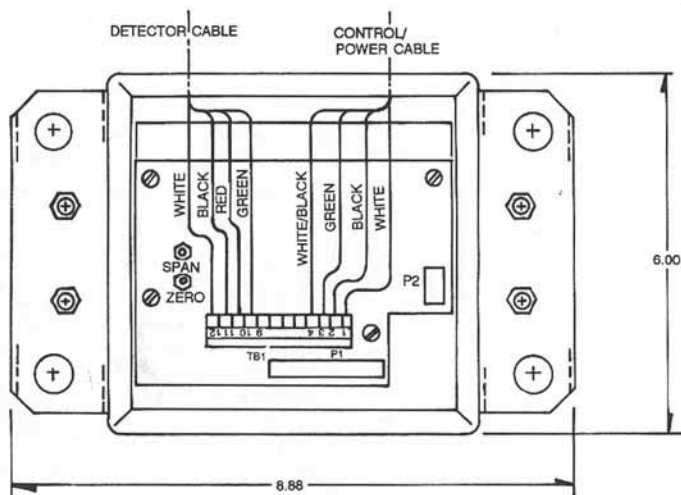

Fig. 2
 140B
 LP & LD
 Control Units
 Outline &
 Wiring Diagram



NOTES:

LP Unit Height
 W/Weld Bars:
 2.60 Inches (Max)

3.50 Inch Clearance
 Required (From Mtg.
 Surface) For Removal
 Of Cover

LD Unit Height
 W/Weld Bars:
 4.10 Inches (Max)

5.00 Inch Clearance
 Required (From Mtg.
 Surface) For Removal
 Of Cover

Fig. 3
 140B
 LD/AUX
 Control Unit
 Outline &
 Wiring Diagram

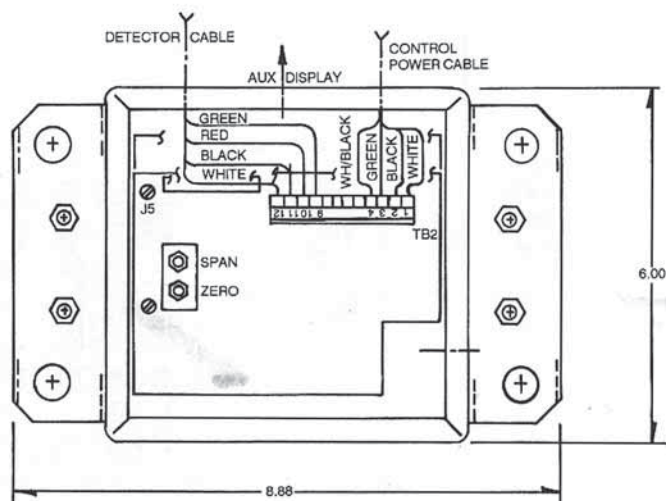

NOTES:

Unit Height
 W/Weld Bars:
 4.10 Inches (Max)

5.00 Inch Clearance
 Required (From Mtg.
 Surface) For Removal
 Of Cover.

Fig. 4
140B
Dual
Interface Unit
Outline & Wiring
Diagram

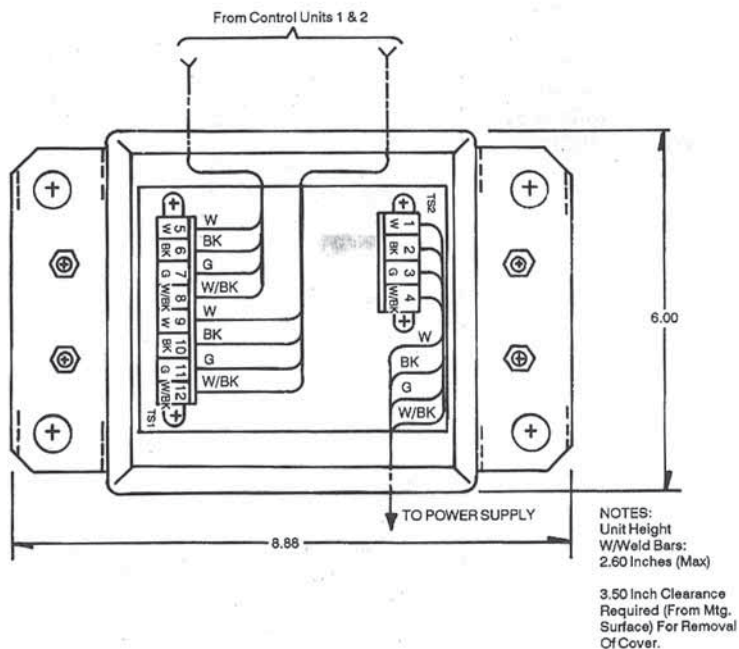

Fig. 5
140B
AC Power
Supply
IN X/P
Outline &
Wiring
Diagram

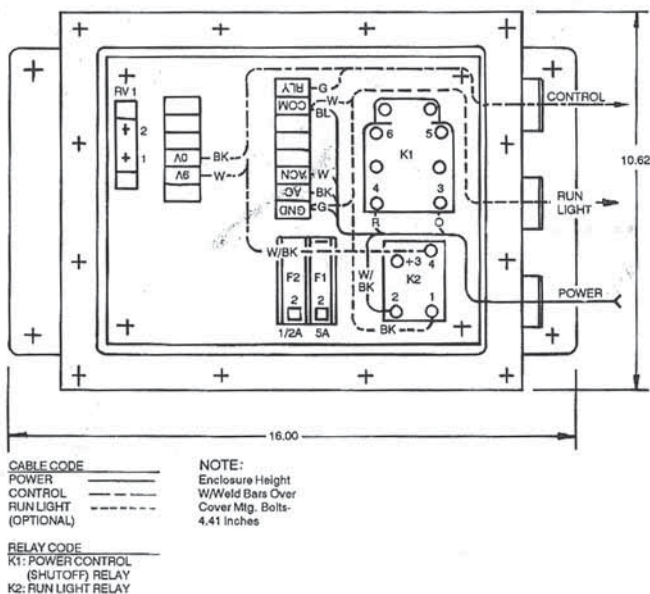

Fig. 6
140B
DC Inverter
IN X/P
Outline &
Wiring
Diagram

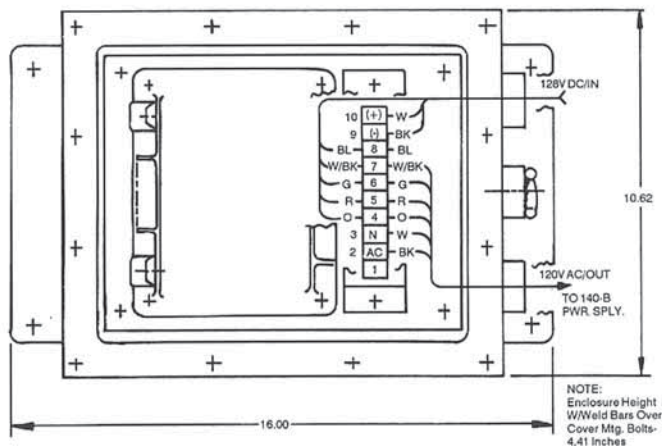
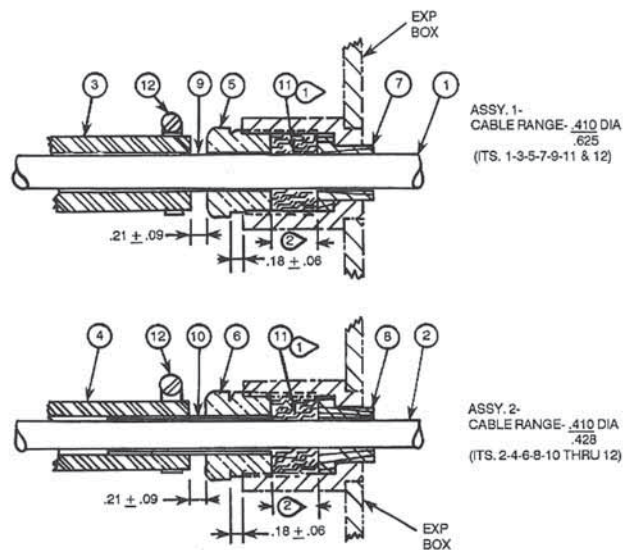

Fig. 7
Explosion
Proof Box
Cable
Entrance/
Gland
Packing Kit



ASSY. NOTE

- ① = Length of packing (IT-11) will vary w/dia. of cable used. Sufficient packing must be used to ensure that tubing (ITS. 9 or 10) will not rotate when gland nut (ITS. 5 or 6) is tightened to dimension specified on drawing.
- ② = Compressed packing Mil. (IT.11) must contact cable jacket for a min. of .50 in.
- ③ SEE MSHA Title 30- 18.37

PARTS LIST

1. Cable (0.625/.410 Range)
2. Cable (0.428/.220 Range)
3. Conduit Hose (.750 ID)
4. Conduit Hose (.625 ID)
5. Gland Nut (.770 NOM ID)
6. Gland Nut (.520 NOM ID)
7. Bushing (.645 NOM ID)
8. Bushing (.455 NOM ID)
9. Tube (.75 NOM. OD.)
10. Tube (.50 NOM. OD.)
11. Packing material
12. Hose clamp

Fig. 8
Model 140B
(Single Detector)
Methane Monitor
System

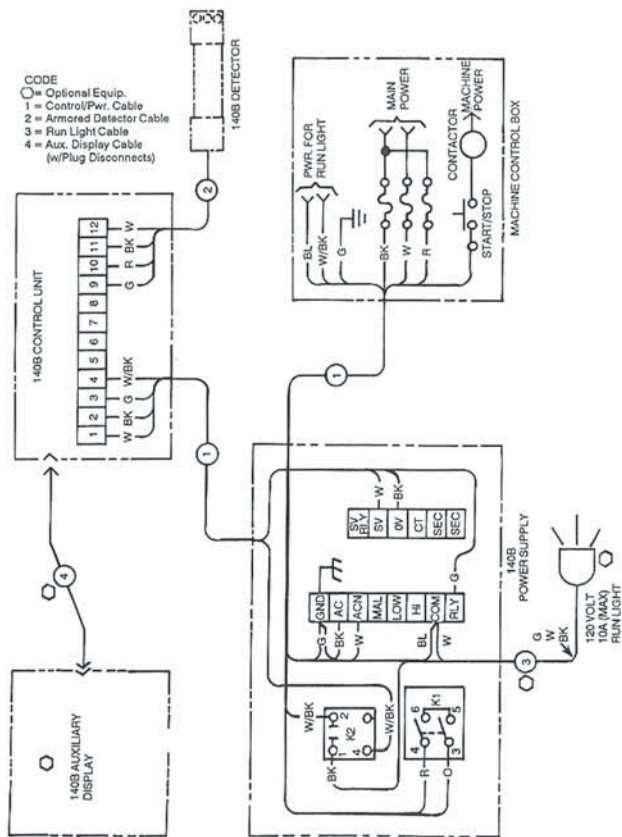

Fig. 10
Model 140B
Roof Bolter
Auxiliary
Panel
Assembly

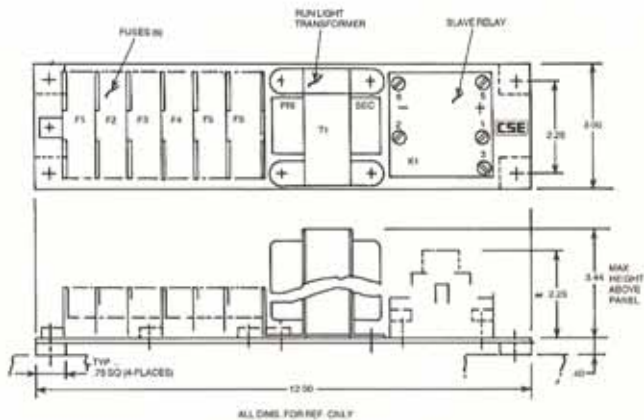

Fig. 11
Roof Bolter
Auxiliary
Panel
Wiring Diagram

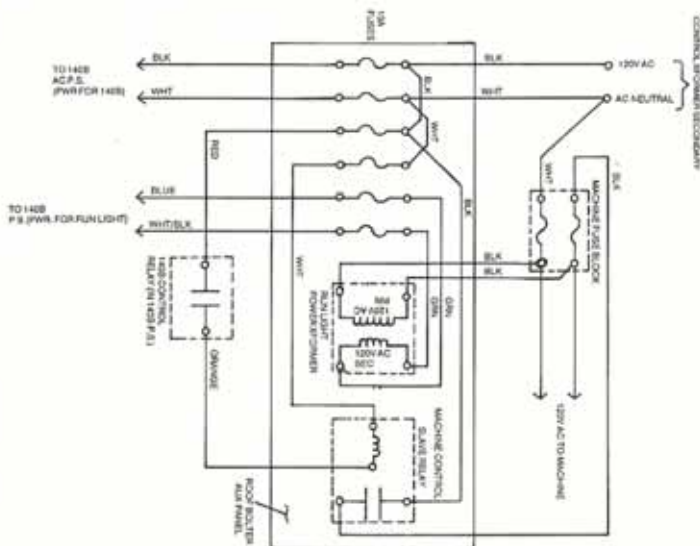

Fig. 12
Model 140B
DC Inverter
Conn. Diag.
Label

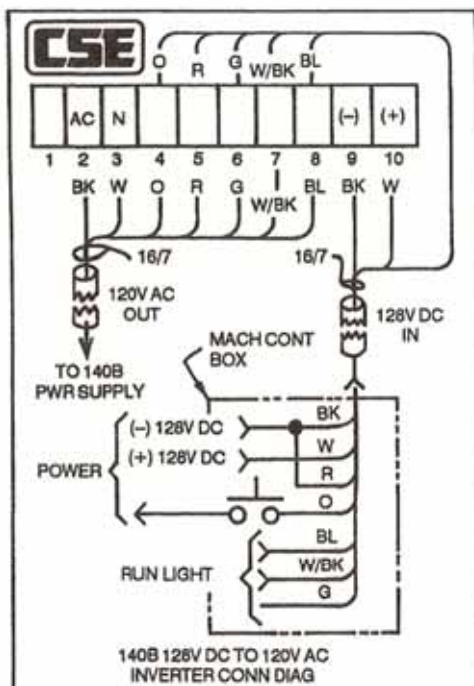
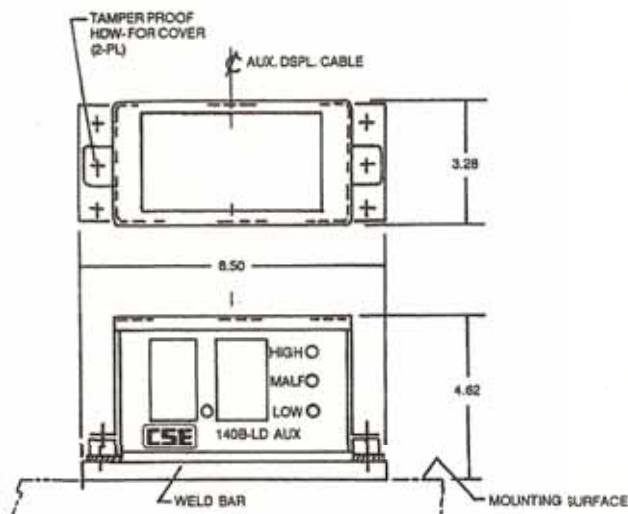

Fig. 13
140B-LD
Auxiliary
Display Unit
Outline





CSE Corporation
600 Seco Road
Monroeville, PA 15146
Fax: 412/856-9203
Phone: 412/856-9200

330-C Harper Park Drive
Harper Industrial Park
Beckley, WV 25801
Fax: 304/255-6214
Phone: 304/255-0541

MSHA Certified

Certified as complying with requirements of the Mine and Health Administration Title 30 CFR, Part 27 (for Schedule 32A), with Certification No. 32A-15/MS. All approved by the Department of Environmental Resources Commonwealth of Pennsylvania; Approval No. BFE.